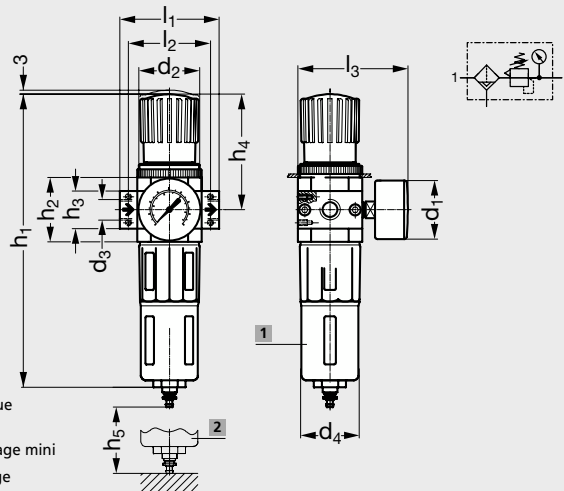

MICHAUD CHAILLYCOMPOSANTS POUR
PNEUMATIQUES ET FLUIDESmodèle **H01**

Filtre régulateur

**UTILISATION**

- Pression d'entrée: 1,5 à 12 bars.
- Pression de service: 0,5 à 12 bars.
- Température: -10°C à +60°C.
- Permet de débarrasser l'air comprimé de toutes impuretés, rouille et eau de condensation.
- Filtration 40 µm.

FOURNITURE

- Manomètre.
- Purgeur de condensats automatique.

Exemple de commande

Référence

H01-FR-B-1/2

| | Famille | d ₃ | d ₁ | d ₂ | d ₄ | l ₁ | l ₂ | l ₃ | h ₁ | h ₄ | h ₅ | h ₂ | h ₃ | Débit nominal (l/min) |
|--------------|---------|----------------|----------------|----------------|----------------|----------------|----------------|----------------|----------------|----------------|----------------|----------------|----------------|-----------------------|
| H01-FR-A-1/8 | A | 1/8" | 41 | M36x1,5 | 38 | 64 | 52 | 76 | 193 | 68 | 60 | 40 | 20 | 750 |
| H01-FR-A-1/4 | A | 1/4" | 41 | M36x1,5 | 38 | 64 | 52 | 76 | 193 | 68 | 60 | 40 | 20 | 1400 |
| H01-FR-B-3/8 | B | 3/8" | 50 | M52x1,5 | 52 | 85 | 70 | 95 | 250 | 99 | 80 | 55 | 32 | 3100 |
| H01-FR-B-1/2 | B | 1/2" | 50 | M52x1,5 | 52 | 85 | 70 | 95 | 250 | 99 | 80 | 55 | 32 | 3400 |
| H01-FR-C-3/4 | C | 3/4" | 50 | M36x1,5 | 65 | 96 | 80 | 107 | 252 | 82 | 90 | 66 | 32 | 9000 |
| H01-FR-C-1 | C | 1" | 50 | M36x1,5 | 65 | 116 | 91 | 107 | 252 | 82 | 90 | 66 | 40 | 10000 |

Produits associés

H00 Page 343



H02 Page 345



H04 Page 347



H06 Page 353



H061 Page 354



H30 Page 458



H32 Page 493



H622 Page 511



H0913 Page 352