

MICHAUD CHAILLYELEMENTS
DE TRANSMISSIONmodèle **F2-11**

Rondelle frein pour écrou de serrage

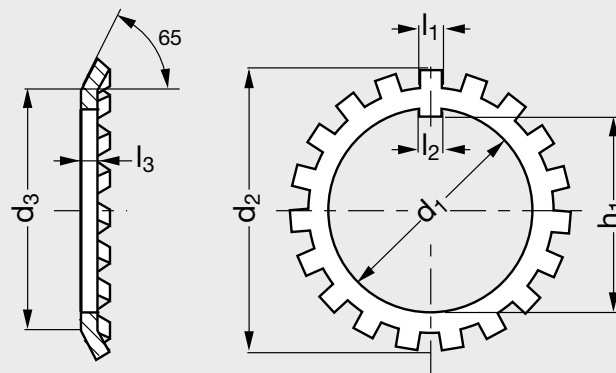

Produit associé



F2-10 Page 1140

MATIÈRE

- Tôle d'acier emboutie.

● Délai maîtrisé ○ Contactez-nous

RéférenceExemple de commande **F2-11-01**

		d_1 x pas	d_2	d_3	l_1	l_2	l_3	h_1	Poids g
F2-11-00	●	10	21	13,5	3	3	1	8,5	1,30
F2-11-01	●	12	25	17	3	3	1	10,5	1,90
F2-11-02	●	15	28	21	4	4	1	13,5	2,50
F2-11-03	●	17	32	24	4	4	1	15,5	3,10
F2-11-04	●	20	36	26	4	4	1	18,5	3,50
F2-11-05	●	25	42	32	5	5	1,25	23	6,40
F2-11-06	●	30	49	38	5	5	1,25	27,5	7,80
F2-11-07	●	35	57	44	5	6	1,25	32,5	10,40

		d_1 x pas	d_2	d_3	l_1	l_2	l_3	h_1	Poids g
F2-11-08	●	40	62	50	6	6	1,25	37,5	12,30
F2-11-09	●	45	69	56	6	6	1,25	42,5	15,20
F2-11-10	●	50	74	61	6	6	1,25	47,5	16,00
F2-11-11	●	55	81	67	7	8	1,25	52,5	19,60
F2-11-12	●	60	86	73	7	8	1,50	57,5	25,30
F2-11-13	●	65	92	79	7	8	1,50	62,5	29,00
F2-11-14	●	70	98	85	8	8	1,50	66,5	33,40
F2-11-15	●	75	104	90	8	8	1,50	71,5	35,60

Rondelle frein pour écrou de serrage

● Délai maîtrisé ○ Contactez-nous

		d ₁ x pas	d ₂	d ₃	l ₁	l ₂	l ₃	h ₁	Poids g
F2-11-16	●	80	112	95	8	10	1,75	76,5	46,40
F2-11-17	●	85	119	102	8	10	1,75	81,5	52,40
F2-11-18	○	90	126	108	10	10	1,75	86,5	62,30
F2-11-19	●	95	133	113	10	10	1,75	91,5	67,00
F2-11-20	●	100	142	120	10	12	1,75	96,5	76,50
F2-11-21	●	105	145	126	12	12	1,75	100,5	82,60
F2-11-22	●	110	154	133	12	12	1,75	105,5	94,00
F2-11-23	●	115	159	137	12	12	2	110,5	108,00
F2-11-24	●	120	164	138	12	14	2	115	105,00
F2-11-25	○	125	170	148	12	14	2	120	118,00
F2-11-26	●	130	175	149	12	14	2	125	113,00

Référence

Exemple de commande **F2-11-01**

		d ₁ x pas	d ₂	d ₃	l ₁	l ₂	l ₃	h ₁	Poids g
F2-11-27	●	135	185	160	14	14	2	130	144,00
F2-11-28	●	140	192	160	14	16	2	135	142,00
F2-11-29	●	145	202	172	14	16	2	140	168,00
F2-11-30	●	150	205	171	14	16	2	145	155,00
F2-11-31	○	155	212	182	16	16	2,50	147,5	209,00
F2-11-32	●	160	217	182	16	18	2,50	154	222,00
F2-11-33	○	165	222	193	16	18	2,50	157,5	241,00
F2-11-34	●	170	232	193	16	18	2,50	164	247,00
F2-11-36	●	180	242	203	18	20	2,50	174	268,00
F2-11-38	●	190	252	214	18	20	2,50	184	278,00
F2-11-40	●	200	262	226	18	20	2,50	194	293,00